

Specifications

Model	Line Voltage (VAC)	Armature Voltage Range (VDC)	Continuous Armature Current (Amps)	Horsepower Range
LGP101-2	115	0 - 90	2.0	1/20 - 1/6
LGP101-10	115	0 - 90	10.0*	1/4 - 1

* Heat sink kit HSK-0001 must be used when the continuous output current is over 5 amps.

AC Line Voltage.....	115 VAC ± 10%, 50/60 Hz, single phase
Form Factor.....	1.37 at base speed
Acceleration Time.....	approx. 2 seconds
Deceleration Time.....	approx. 2 seconds
Analog Input Range (NEG to POS).....	0 - 10 VDC
Input Impedance (NEG to POS).....	1K ohms
Load Regulation.....	1% base speed or better
Speed Range.....	60:1
Vibration (0 - 50 Hz).....	0.5G maximum
(>50 Hz).....	0.1G maximum
Ambient Temperature Range.....	10°C - 55°C
Weight.....	0.7 lbs
Safety Certifications.....	UL/cUL Recognized Equipment, file # E132235 CSA Certified Component, file # LR41380

Safety Warnings

READ ALL SAFETY WARNINGS BEFORE INSTALLING THIS EQUIPMENT

- **DO NOT INSTALL, REMOVE, OR REWIRE THIS EQUIPMENT WITH POWER APPLIED.** Have a qualified electrical technician install, adjust and service this equipment. Follow the National Electrical Code and all other applicable electrical and safety codes, including the provisions of the Occupational Safety and Health Act (OSHA), when installing equipment.
- **Circuit potentials are at 115 VAC above earth ground.** Avoid direct contact with the printed circuit board or with circuit elements to prevent the risk of serious injury or fatality. Use a non-metallic screwdriver for adjusting the calibration trim pots. Use approved personal protection equipment and insulated tools if working on this drive with power applied.
- Reduce the chance of an electrical fire, shock, or explosion by using proper grounding techniques, over-current protection, thermal protection, and enclosure. Follow sound maintenance procedures.
- **ACE strongly recommends the installation of a master power switch in the line voltage input.** The switch contacts should be rated for 250 VAC and 200% of motor nameplate current.
- **Removing AC line power is the only acceptable method for emergency stopping.** Do not use dynamic braking, decelerating to minimum speed, or coasting to a stop for emergency stopping. They may not stop a drive that is malfunctioning. Removing AC line power is the only acceptable method for emergency stopping.
- Line starting and stopping (applying and removing AC line voltage) is recommended for infrequent starting and stopping of a drive only. Dynamic braking, decelerating to minimum speed, or coasting to a stop is recommended for frequent starts and stops. Frequent starting and stopping can produce high torque. This may cause damage to motors.
- **Do not disconnect any of the motor leads from the drive** unless power is removed or the drive is disabled. Opening any one lead while the drive is running may destroy the drive.
- Under no circumstances should power and logic level wires be bundled together.
- Be sure potentiometer tabs do not make contact with the potentiometer's body. Grounding the input will cause damage to the drive.

Dimensions

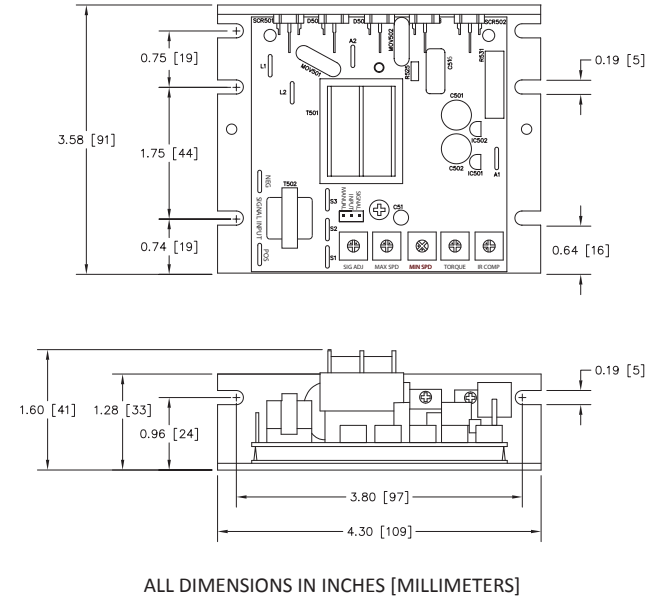

Installation

Mounting

- Drive components are sensitive to electrostatic discharge. Avoid direct contact with the circuit board. Hold the drive by the chassis or heat sink only.
- Protect the drive from dirt, moisture, and accidental contact.
- Provide sufficient room for access to the terminals and calibration trim pots.
- Mount the drive away from heat sources. Operate the drive within the specified ambient operating temperature range.
- Prevent loose connections by avoiding excessive vibration of the drive.
- Mount the drive with its board in either a horizontal or vertical plane. Eight 0.19" (5 mm) wide slots in the chassis accept #8 pan head screws. Fasten either the large base or the narrow flange of the chassis to the subplate.
- The chassis should be earth grounded. Use a star washer beneath the head of at least one of the mounting screws to penetrate the anodized chassis surface and to reach bare metal.

Heat Sinking

The LGP101-10 requires an additional heat sink when the continuous armature current is above 5 amps. Use ACE heat sink kit part number HSK-0001. Use a thermally conductive heat sink compound (such as Dow Corning 340® Heat Sink Compound) between the chassis and the heat sink surface for optimal heat transfer.

Wiring

Use 18 - 24 AWG wire for logic wiring. Use 14 - 16 AWG wire for AC line and motor wiring.

Shielding Guidelines

As a general rule, ACE recommends shielding of all conductors. If it is not practical to shield power conductors, ACE recommends shielding all logic-level leads. If shielding of logic-level leads is not practical, the user should twist all logic leads with themselves to minimize induced noise. It may be necessary to earth ground the shielded cable. If noise is produced by devices other than the drive, ground the shield at the drive end. If noise is generated by the drive, ground the shield at the end away from the drive. Do not ground both ends of the shield.

Fusing

ACE drives require an external line fuse for protection. Use fast acting fuses rated for 250 VAC or higher and 150% of the maximum armature current. Fuse the HOT leg of the AC line.

Connections

POWER

Line Input

Connect the AC line power leads to terminals L1 and L2. ACE recommends the use of a double-pole, single-throw master power switch. The switch should be rated at a minimum of 250 VAC and 200% of motor current.

Motor

Connect the DC armature leads to terminals A1 and A2. If the motor does not spin in the desired direction, power down the drive and reverse these connections.

LOGIC

Speed Potentiometer

Use a 10K ohm, 1/4 W potentiometer for speed control. Connect the counter-clockwise end of the potentiometer to S1, the wiper to S2, and the clockwise end to S3. If the potentiometer works inversely of desired functionality, (i.e. to increase motor speed, you must turn the potentiometer counterclockwise), power off the drive and swap the S1 and S3 connections.

Analog Input Signal Range

Instead of using a speed adjust potentiometer, LGP series drives may be wired to follow a 0 - 10 VDC analog input signal. Because these drives have built in isolation, the input signal can be grounded or ungrounded (floating). Connect the signal common to (-) to terminal NEG and the signal input (+) to terminal POS. Refer to the STARTUP section for MANUAL / SIGNAL jumper settings.

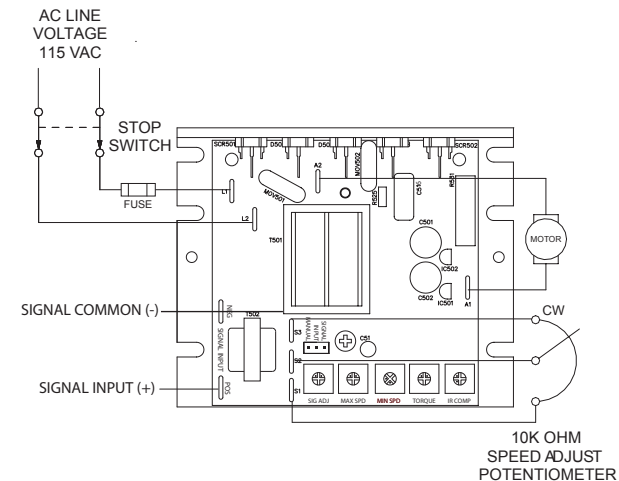

10K OHM
SPEED ADJUST
POTENTIOMETER

Startup

JUMPERS

Manual / Signal Jumper

If using a potentiometer, jumper pins INPUT and MANUAL. If using a 0 - 10 VDC analog signal, jumper pins INPUT and SIGNAL.

Manual / Signal Jumper

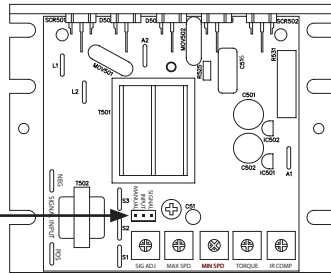

STARTUP

- Verify that no foreign conductive material is present on the printed circuit board.
- Ensure that the jumper is properly set.

1. Turn the speed adjust potentiometer full counterclockwise (CCW) or set the analog input voltage signal to minimum.
2. Apply AC line voltage.
3. Slowly advance the speed adjust potentiometer clockwise (CW) or increase the analog input voltage signal. The motor slowly accelerates as the potentiometer is turned CW or as the analog input signal is increased. Continue until the desired speed is reached.
4. Remove AC line voltage from the drive to coast the motor to a stop.

Operation

DECELERATING & STOPPING

Decelerate to Minimum Speed

The switches shown below may be used to decelerate a motor to a minimum speed. Opening the switch on S3 or on POS decelerates the motor from set speed to a minimum speed determined by the MIN SPD trim pot setting. If the MIN SPD trim pot is set full CCW, the motor decelerates to zero speed when the switch is opened. By closing the switch, the motor accelerates to set speed.

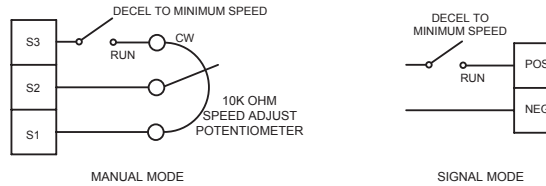

Decelerate to Zero Speed (Dynamic Brake)

Dynamic braking may be used to rapidly stop a motor. The MIN SPD trim pot must be set for zero speed. For the RUN/BRAKE switch, use a two pole, two position switch rated for at least the armature voltage rating and 150% of the armature current rating. For the dynamic brake resistor, use a 40 watt minimum, high power, wirewound resistor. Sizing the dynamic brake resistor depends on load inertia, motor voltage, and braking time. Use a lower-value, higher-wattage dynamic brake resistor to stop a motor more rapidly. Recommended value is 15 ohms for a 90 VDC motor.

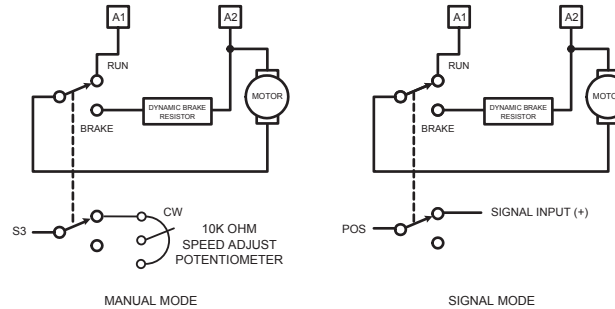

REVERSING

Reversing with a Dynamic Brake

A dynamic brake may be used when reversing the motor direction. The MIN SPD trim pot must be set for zero speed. Use a three pole, three position switch rated for at least the armature voltage rating and 150% of the armature current rating. For the dynamic brake resistor, use a 40 watt minimum, high power, wirewound resistor. Sizing the dynamic brake resistor depends on load inertia, motor voltage, and braking time. Use a lower-value, higher-wattage dynamic brake resistor to stop a motor more rapidly. Recommended value is 15 ohms for a 90 VDC motor.

The motor must come to a complete stop before changing directions.

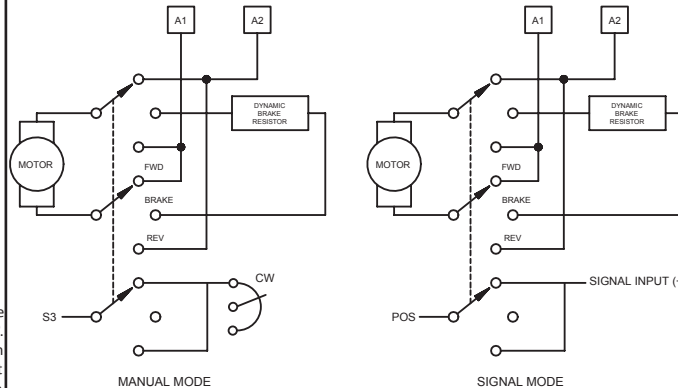

Calibration

Minimum Speed (MIN SPD): The MIN SPD setting determines the minimum motor speed when the speed adjust potentiometer is set for minimum speed. It is factory set for zero speed. To calibrate the MIN SPD:

1. Set the MIN SPD trim pot full CCW.
2. Set the speed adjust potentiometer for minimum speed.
3. Adjust the MIN SPD trim pot until the desired minimum speed is reached or is just at the threshold of rotation.

Maximum Speed (MAX SPD): The MAX SPD setting determines the maximum motor speed when the speed adjust potentiometer is set for maximum speed in Manual mode. To calibrate the MAX SPD:

1. Set the MAX SPD trim pot full CCW.
2. Set the speed adjust potentiometer for maximum speed.
3. Adjust the MAX SPD trim pot until the desired maximum speed is reached.

Signal Adjust (SIG ADJ): The SIG ADJ setting determines the maximum motor speed when the input voltage signal is set for maximum speed in Signal mode. To calibrate the SIG ADJ:

1. Set the SIG ADJ trim pot full CCW.
2. Set the input voltage signal for maximum speed.
3. Adjust the SIG ADJ trim pot until the desired maximum speed is reached.

Check the MIN SPD and MAX SPD / SIG ADJ adjustments after recalibrating to verify that the motor runs at the desired minimum and maximum speed.

Torque (TORQUE): The TORQUE setting determines the maximum torque for accelerating and driving the motor. To calibrate the TORQUE:

1. With the power disconnected from the drive, connect a DC ammeter in series with the armature.
2. Set the TORQUE trim pot to minimum (full CCW).
3. Set the speed adjust potentiometer or input voltage signal to maximum speed.
4. Carefully lock the motor armature. Be sure that the motor is firmly mounted.
5. Apply line power. The motor should be stopped.
6. Slowly adjust the TORQUE trim pot CW until the armature current is 150% of motor rated armature current. **Continuous operation beyond this rating may damage the motor.**
7. Turn the speed adjust potentiometer CCW or decrease the input voltage signal.
8. Remove line power.
9. Remove the stall from the motor.
10. Remove the ammeter in series with the motor armature if it is no longer needed.

IR Compensation (IR COMP): The IR COMP setting determines the degree to which motor speed is held constant as the motor load changes. To calibrate the IR COMP:

1. Set the IR COMP trim pot full CCW.
2. Increase the speed adjust potentiometer or input voltage signal until the motor runs at midspeed without load. A handheld tachometer may be used to measure motor speed.
3. Load the motor armature to its full load armature current rating. The motor should slow down.
4. While keeping the load on the motor, rotate the IR COMP trim pot until the motor runs at the speed measured in step 2. If the motor oscillates (overcompensation), the IR COMP trim pot may be set too high (CW). Turn the IR COMP trim pot CCW to stabilize the motor.
5. Unload the motor.